

HAFCO METALMASTER

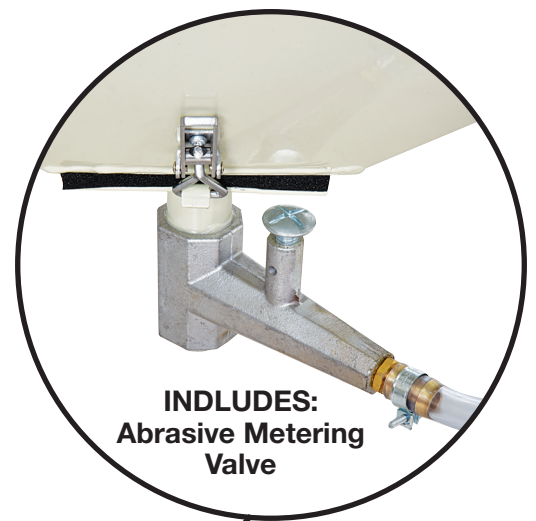

INCLUDES:
Abrasive Metering
Valve



Edition : 2.0
Date: (05/26)

Instruction Manual

SANDBLASTING CABINET SBC-990

Order Code: (S305)

MACHINE DETAILS

MACHINE	Sandblasting Cabinet
MODEL NO.	SBC-990
SERIAL NO.	
DATE OF MANF.	

DISTRIBUTED BY



www.machineryhouse.com.au

www.machineryhouse.co.nz

NOTE:

This manual is only for your reference. At the time of the compiling of this manual every effort to be exact with the instructions, specifications, drawings, and photographs of the machine was taken. Owing to the continuous improvement of the HAFCO METALMASTER machine, changes may be made at any time without obligation or notice. Please ensure the local voltage is the same as listed on the specification plate before operating any electric machine.

SAFETY SYMBOLS

The purpose of safety symbols is to attract your attention to possible hazardous conditions



WARNING

Indicates a potentially hazardous situation causing injury or death



CAUTION

Indicates an alert against unsafe practices.

Note:

Used to alert the user to useful information



NOTE:

In order to see the type and model of the machine, please see the specification plate. Usually found on the back of the machine. See example (Fig.1)

Fig.1

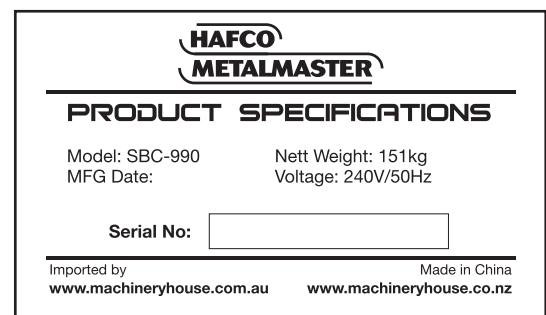

CONTENTS

1. GENERAL MACHINE INFORMATION	
1.1 Specifications	4
1.2 Includes	4
1.3 Machine Dimensions	4
1.4 Identification	5
2. SAFETY	
2.1 General Machine Safety.....	6
2.2 Specific Safety For Sand Blast Cabinets.....	9
3. POWER SUPPLY	
3.1 Electrical Requirements	10
3.2 Full Load Current Rating.....	10
4. SETUP	
4.1 Unpacking.....	11
4.2 Clean Up.....	11
4.3 Site Preparation	11
4.4 Lifting Instructions	11
4.5 Anchoring To The Floor.....	12
4.6 Assembly	13
4.7 Air Supply	17
5. OPERATION	
5.1 Controls	18
5.2 Basic Operation	21
5.3 Blasting Media.....	23
5.4 Troubleshooting	24
6. MAINTENANCE	
6.1 Schedule.....	25
6.2 Cleaning The Filter.....	25
7.0 RECOMMENDED ACCESSORIES.....	26
SPARE PARTS	27



WARNING!

The machine is the sole responsibility of the owner for its safe use. This responsibility includes but is not limited to proper installation in a safe environment, personnel training, proper inspection and maintenance, manual availability and comprehension. The manufacturer will not be held liable for injury or property damage from negligence, improper training, machine modifications or misuse.

1.1 SPECIFICATIONS

Order Code	S305
MODEL	SBC-990
Approx. Inside Cabinet Size (L x W x H) (mm)	1180 x 870 x 450-810
Internal Light (type)	LED Light
Recommended Free Air Delivery (FAD) @ 100psi	24 CFM (680 L/min)
Suggested Operating Air Pressure Range	60 ~ 120psi
Maximum Air Pressure	120psi
Dust Collector Filter Rating	5 microns
Floor Space with Door Closed/Open (L x W x H)	1330 x 1350 x 1750/2180mm
Shipping Dimension	1330 x 960 x 1070mm
Nett Weight	160kg

1.2 INCLUDES

- 5 x Replacement Light Films
- 5 x Replacement Window Films
- 3 x Spare Ceramic Tips



1.3 MACHINE DIMENSIONS

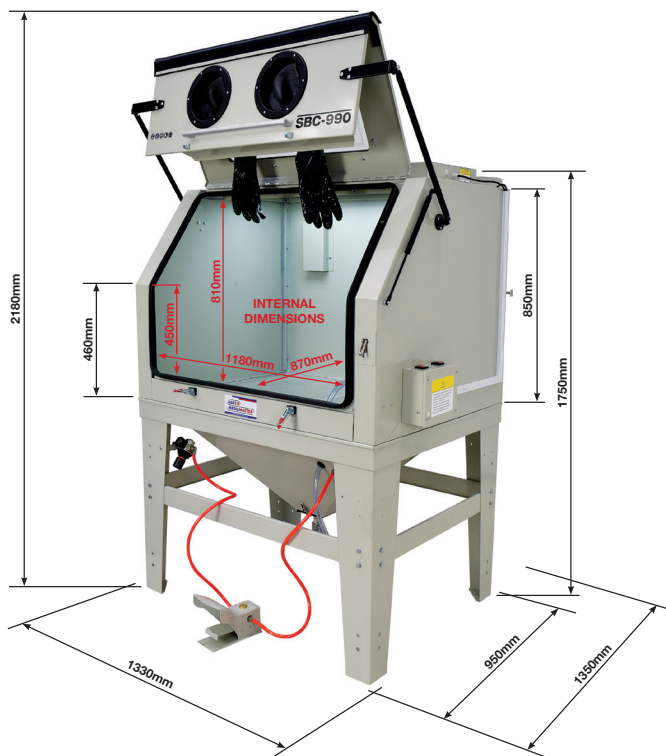

1.4 IDENTIFICATION

Become familiar with the names and locations of the controls and features shown below to better understand the instructions when mentioned later in this manual.

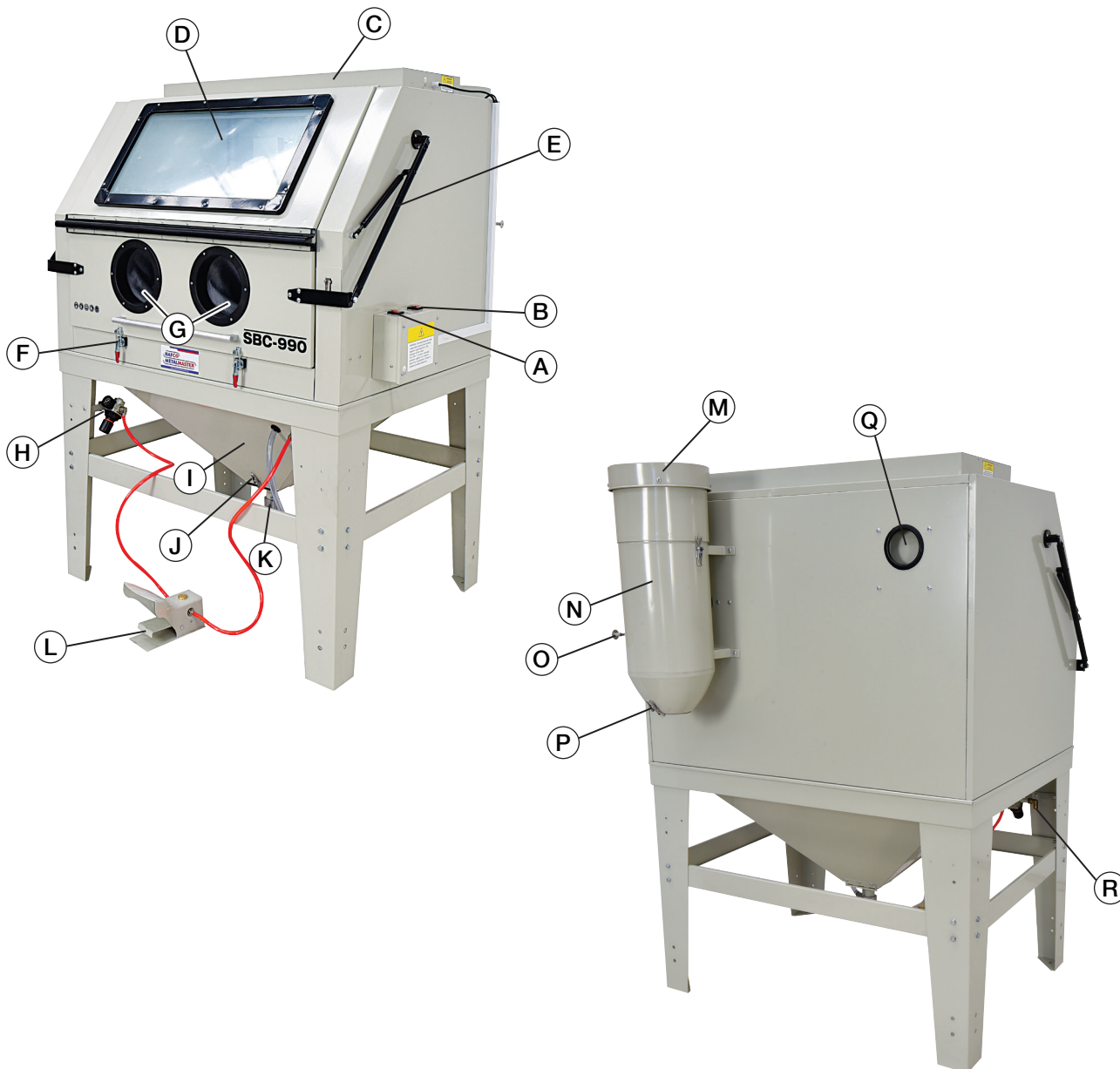

A	ON/OFF Switch - Light	J	Hopper Emptying Latch
B	ON/OFF Switch - Dust Collector	K	Abrasive Metering Valve
C	LED Light Assembly	L	Foot Pedal Blasting Switch
D	Viewing Window	M	Dust Collector Motor
E	Gas Strut Door Support	N	Dust Collector System
F	Front Access Door Latch	O	Dust Collector Shaker Push Handle
G	Gloves	P	Dust Collector Emptying Hatch
H	Pressure Gauge Assembly	Q	Air Intake Breather
I	Hopper	R	Compressed Air Inlet

2.0 SAFETY

2.1 GENERAL MACHINE SAFETY

DO NOT use this machine unless you have read this manual or have been instructed in the safe use and operation of this machine.



WARNING!

This manual provides safety instructions on the proper setup, operation, maintenance, and service of this machine. Save this manual, refer to it often, and use it to instruct other operators.

Failure to read, understand and follow the instructions in this manual may result in fire or serious personal injury—including amputation, electrocution, or death.

The owner of this machine is solely responsible for its safe use. This responsibility includes, but is not limited to proper installation in a safe environment, personnel training and authorization to use, proper inspection and maintenance, manual availability and comprehension, of the application of the safety devices, integrity, and the use of personal protective equipment.

The manufacturer will not be held liable for injury or property damage from negligence, improper training, machine modifications or misuse.



- ✓ Always wear safety glasses or goggles.
- ✓ Wear appropriate safety footwear.
- ✓ Wear respiratory protection where required.
- ✓ Gloves should never be worn while operating the machine controls, and only worn when handling the workpiece.
- ✓ Wear hearing protection in areas > 85 dBA. If you have trouble hearing someone speak from one metre (three feet) away, the noise level from the machine may be hazardous.
- ✓ **DISCONNECT THE MACHINE FROM THE POWER** when making adjustments or servicing.
- ✓ Check and adjust all safety devices before each job.
- ✓ Ensure that guards are in position and in good working condition before operating.
- ✓ Ensure all machines have a start/stop button within easy reach of the operator.
- ✓ Each machine should have only one operator at a time. However, everyone should know how to stop the machine in an emergency.

2.1 GENERAL MACHINE SAFETY CONT.

- ✓ Ensure that keys and adjusting wrenches have been removed from the machine before turning on the power. Appropriate storage for tooling should be provided.
- ✓ Ensure that all cutting tools and blades are clean and sharp. They should be able to cut freely without being forced.
- ✓ Stop the machine before measuring, cleaning or making any adjustments.
- ✓ Wait until the machine has stopped running to clear cuttings with a vacuum, brush or rake.
- ✓ Keep hands away from the cutting head and all moving parts.
- ✓ Avoid awkward operations and hand positions. A sudden slip could cause the hand to move into the cutting tool or blade.
- ✓ Return all portable tooling to their proper storage place after use.
- ✓ Clean all tools after use.
- ✓ Keep work area clean. Floors should be level and have a non-slip surface.
- ✓ Use good lighting so that the work piece, cutting blades, and machine controls can be seen clearly. Position any shade lighting sources so that they do not cause any glare or reflections.
- ✓ Ensure there is enough room around the machine to do the job safely.
- ✓ Obtain first aid immediately for all injuries.
- ✓ Understand that the health and fire hazards can vary from material to material. Make sure all appropriate precautions are taken.
- ✓ Clean machines and the surrounding area when the operation is finished.
- ✓ Use proper lock out procedures when servicing or cleaning the machines or power tools.

DO NOT

- ✗ Do not distract an operator. Horseplay can lead to injuries and should be strictly prohibited.
- ✗ Do not wear loose clothing, gloves, neckties, rings, bracelets or other jewellery that can become entangled in moving parts. Confine long hair.
- ✗ Do not handle cuttings by hand because they are very sharp. Do not free a stalled cutter without turning the power off first. Do not clean hands with cutting fluids.
- ✗ Do not use rags or wear gloves near moving parts of machines.
- ✗ Do not use compressed air to blow debris from machines or to clean dirt from clothes.
- ✗ Do not force the machine. It will do the job safer and better at the rate for which it was designed.



WARNING!

Before operating any machine, take time to read and understand all safety signs and symbols. If not understood seek explanation from your supervisor.

2.1 GENERAL MACHINE SAFETY CONT.

HAZARDS ASSOCIATED WITH MACHINES include, but are not limited to:

- Being struck by ejected parts of the machinery
- Being struck by material ejected from the machinery
- Contact or entanglement with the machinery
- Contact or entanglement with any material in motion

Health Hazards (other than physical injury caused by moving parts)

- Chemicals hazards that can irritate, burn, or pass through the skin
- Airborne items that can be inhaled, such as oil mist, metal fumes, solvents, and dust
- Heat, noise, and vibration
- Ionizing or non-ionizing radiation (X-ray, lasers, etc.)
- Biological contamination and waste
- Soft tissue injuries (for example, to the hands, arms, shoulders, back, or neck) resulting from repetitive motion, awkward posture, extended lifting, and pressure grip.

Other Hazards

- Slips and falls from and around machinery during maintenance
- Unstable equipment that is not secured against falling over
- Safe access to/from machines (access, egress)
- Fire or explosion
- Pressure injection injuries from the release of fluids and gases under high pressure
- Electrical Hazards, such as electrocution from faulty or ungrounded electrical components
- Environment in which the machine is used (in a machine shop, or on a work site)



WARNING!

Machines are safeguarded to protect the operator from injury or death with the placement of guards. Machines must not be operated with the guards removed or damaged.

2.2 SPECIFIC SAFETY FOR BLAST CABINETS

DO NOT use this machine unless you have been instructed in its safe use and operation and have read and understood this manual



Safety glasses must be worn at all times in work areas



Long and loose hair must be contained or restrained



Sturdy footwear must be worn at all times in work areas



Close fitting/protective clothing must be worn



Always wear hearing protection when operating this machine.



A mask must be worn when excessive airborne dust is created

PERSONAL PROTECTION EQUIPMENT. Media blasting presents a real hazard of silicosis and other lung contamination injuries! These injuries are permanent and can get worse over time. If you use media blasting equipment without the proper head gear, eye protection, and respirator, your lungs and eyes may become permanently damaged. DO NOT use this blast cabinet unless you know how to use it. Protect yourself correctly, and keep all unprotected bystanders away.

ALWAYS use approved protective equipment and an acceptable respirator type.

SAFE MEDIA BLASTING. Do not use system over the rated PSI or lines and seals may burst and cause injury.

SAFE DUST EXPOSURE. To prevent dust exposure, always secure the door(s) before beginning media blasting operations.

LOADING & UNLOADING. To prevent accidental blasting injury, disconnect the air supply before loading or unloading the workpiece from the blast cabinet.

WHEN FINISHED. To prevent accidental blasting injury, disconnect the air supply when finished with the blast cabinet.

SAFE ENVIRONMENT. To avoid media escaping from the cabinet or to prevent an entrapment hazard for animals or children, always close and latch shut the blast cabinet doors when not in use.

CORRECT LIGHTING. To prevent ballast overload and possible fire, only install lamps that are the same voltage and wattage.

MAINTAINING BLAST CABINET. To prevent accidental contamination of shop air, check the blast cabinet for any leaks before use, and reseal immediately.

MAINTAINING COMPONENTS. To prevent accidental contamination or blast injuries, replace tips, hoses, lenses, and gloves when they become worn.



WARNING

Some dust created by power sanding, sawing, grinding, drilling, and other construction activities contains chemicals known to cause cancer, birth defects or other reproductive harm. Some examples of these chemicals are:

- *Lead from lead-based paints.*
- *Crystalline silica from bricks, cement and other masonry products.*
- *Arsenic and chromium from chemically-treated lumber.*

To reduce your exposure to these chemicals: Work in a well ventilated area with protection

3. POWER SUPPLY

3.1 ELECTRICAL INSTALLATION

Place the machine near an existing power source. Make sure all power cords are protected from traffic, material handling, moisture, chemicals, or other hazards. Make sure there is access to a means of disconnecting the power source. The electrical circuit must meet the requirements for 240V.

NOTE : The use of an extension cord is not recommended as it may decrease the life of electrical components on your machine.

ELECTRICAL REQUIREMENTS

Nominal Voltage.....	240V
Cycle.....	50 Hz
Phase.....	Single Phase
Power Supply Circuit.....	10 Amps

(Full load current rating is on the specification plate of the dust collector.)

3.2 FULL-LOAD CURRENT RATING

The full-load current rating is the amperage a machine draws when running at 100% of the output power. Where machines have more than one motor, the full load current is the amperage drawn by the largest motor or a total of all the motors and electrical devices that might operate at one time during normal operations.

It should be noted that the full-load current is not the maximum amount of amps that the machine will draw. If the machine is overloaded, it will draw additional amps beyond the full-load rating and if the machine is overloaded for a long period of time, damage, overheating, or fire may be caused to the motor and circuitry.

This is especially true if connected to an undersized circuit or a long extension lead. To reduce the risk of these hazards, avoid overloading the machine during operation and make sure it is connected to a power supply circuit that meets the requirements.



4 SETUP

4.1 UNPACKING

This machine was carefully packaged for safe transport. When unpacking, separate all enclosed items from packaging materials and inspect them for shipping damage. If items are damaged, please contact your distributor.

NOTE: *Save all the packaging materials until you are completely satisfied with the machine and have resolved any issues with the distributor, or the shipping agent.*

4.2 CLEAN - UP

The unpainted surfaces of the machine have been coated with a waxy oil to protect them from corrosion during shipment. Remove the protective coating with a solvent cleaner or a citrus based degreaser.

Optimum performance from your machine will be achieved when you clean all moving parts or sliding contact surfaces that are coated with rust prevented products.

It is advised to avoid chlorine based solvents, such as acetone or brake parts cleaner, as they will damage painted surfaces and strip metal should they come in contact. Always follow the manufacturer's instructions when using any type of cleaning product.

4.3 SITE PREPARATION

When selecting the site for the machine, consider the largest size of workpiece that will be processed through the machine and provide enough space around the machine for operating the machine safely. Consideration should be given to the installation of auxiliary equipment. Leave enough space around the machine to open or remove doors/covers as required for the maintenance and service as described in this manual.

It is recommended that the machine is anchored to the floor to prevent tipping or shifting. It also reduces vibration that may occur during operation.

4.4 LIFTING INSTRUCTIONS



This machine is extremely heavy.

Serious personal injury may occur if safe moving methods are not followed. To be safe, you will need assistance and power equipment when moving the shipping crate and removing the machine from the crate.



On the day that the machine arrives, make sure that a forklift or lifting device, with sufficient capacity is available to unload the machine from the vehicle. Ensure access to the chosen site is clear and that doors and ceilings are sufficiently high and wide enough to receive the machine.



WARNING. *Make sure everyone is away from the load before hoisting. The load must be under control when lowering loads or when the load is suspended. Rigging and crane operation must be carried out by persons with approved qualifications.*

4.5 ANCHORING TO THE FLOOR

The machine is best mounted on a concrete slab. Masonry anchors with bolts are the best way to anchor machinery, because the anchors sit flush with the floor surface, making it easy to unbolt and move the machine later, if needed. (Fig. 4.1)

Machine Mounting Options

Although it is not required Hafco recommends that you secure your machine to the floor. Masonry anchors with bolts are the best way to anchor machinery, because the anchors sit flush with the floor surface, making it easy to unbolt and move the machine later, if needed. (Fig. 4.1) Other methods of mounting is the use of machine mounts which also help with the levelling of the machine and isolating vibration. (Fig. 4.2)

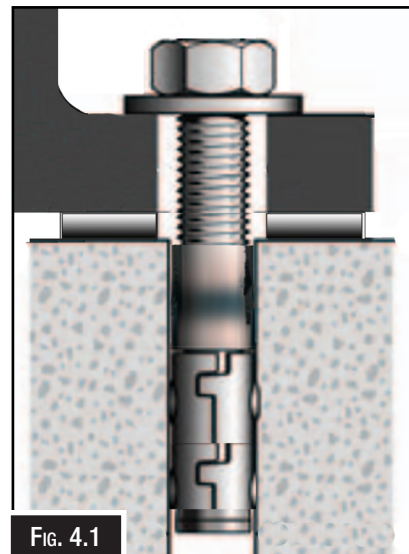

Fig. 4.1

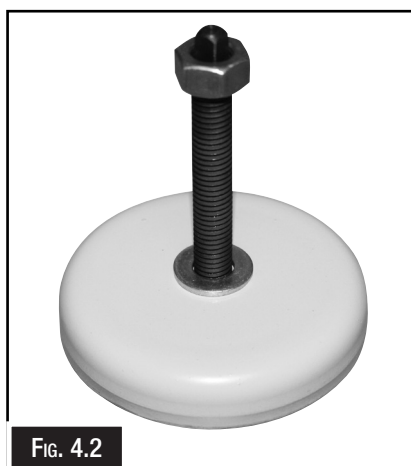

Fig. 4.2



CAUTION!

Do not install the machine in areas that are wet, cluttered, or have poor lighting.

4.6 ASSEMBLY

The machine must be fully assembled before it can be operated. First clean any parts that are coated in rust preventative to ensure the assembly process can proceed smoothly.

Stand and Body Assembly:

1. Carefully unpack the sandblast cabinet near the location where it will be installed.
2. Open the top of the crate and remove all loose parts from around the cabinet. Next, remove the crate sides and take out all remaining components stored inside the cabinet.
3. Assemble the stand using the supplied M8 x 20mm bolts, flat washers, and spring washers. (Fig. 4.3)
4. Place the stand in an upright position and place the hopper on the stand. Now install the foam seal on outer top edge of the hopper. (Fig. 4.4)
5. With assistance, lift the blast cabinet and carefully position it onto the hopper (**NOTE:** Ensure Holes of hopper are at the front). Lift the double-fold door for access and secure the upper cabinet using 22 x M6 x 16mm round head screws and washers. (Fig. 4.5)
6. Attach the bracket with the pressure gauge to the left front leg with the two M6 x 12mm screws, lock washers and nuts as shown (A). (Fig. 4.6)



FIG. 4.3

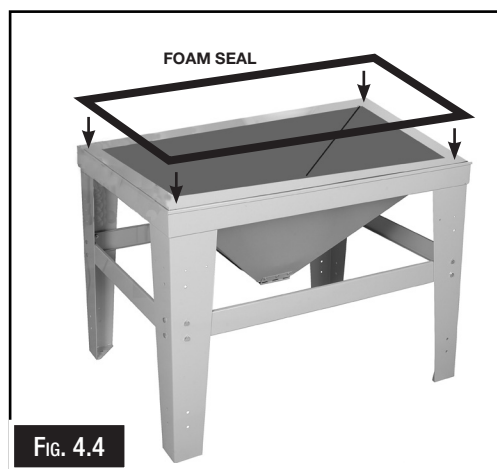

FIG. 4.4

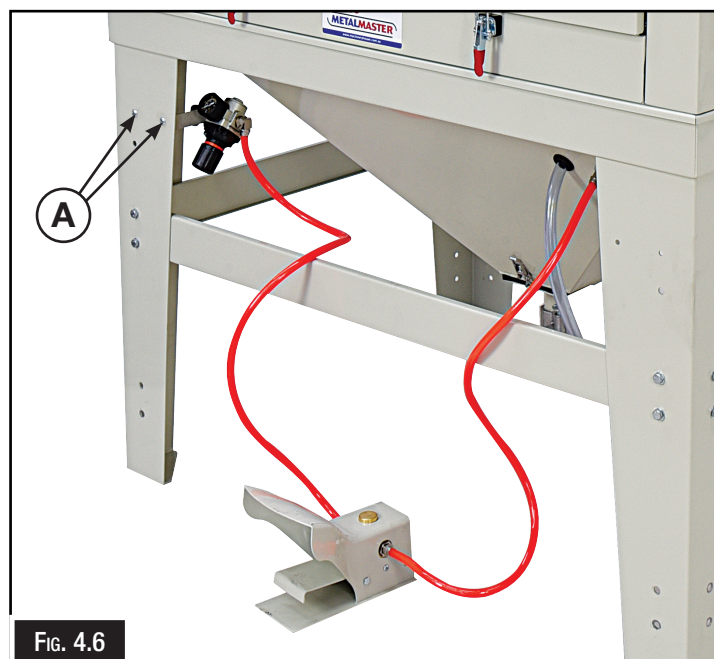

FIG. 4.6



FIG. 4.5

4.6 ASSEMBLY CONT.

7. From inside the cabinet find the air fitting (A) on the end of the pipe that comes out of the door safety valve assembly. Remove the tube nut, threaded sleeve and washer.
8. Push the fitting through the hole in the front right top of the hopper (B). Then refit the washer then the threaded sleeve and tighten. (See Fig. 4.8)
9. Connect the air line from the outgoing side of the foot pedal to the air fitting on the right-hand top side of the hopper (E). Ensure the securing nut is tightened firmly. (See Fig. 4.9)
10. From inside the cabinet, pull the clear air tube through the left-hand hole in the hopper. Attach the tube (F) to the metering valve and secure it firmly using the hose clamp provided. (See Fig. 4.10)

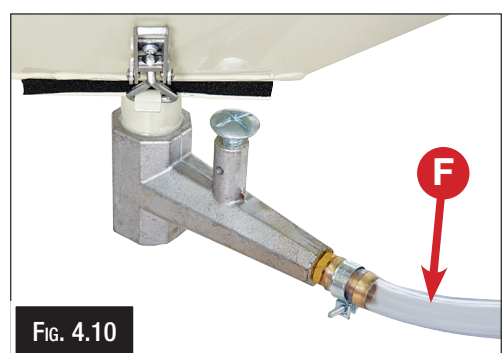
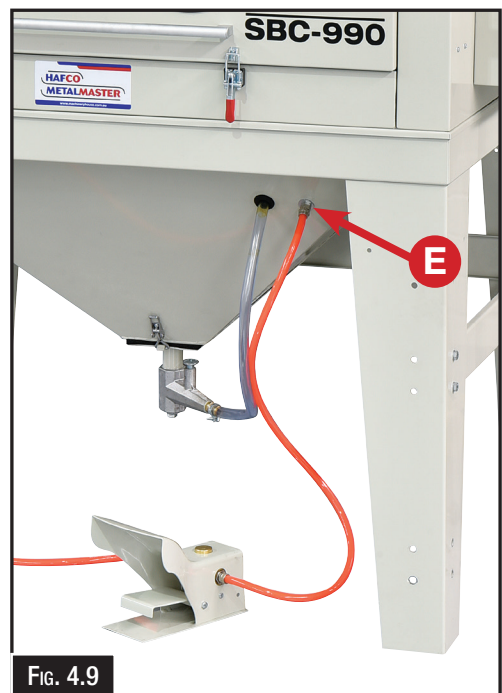
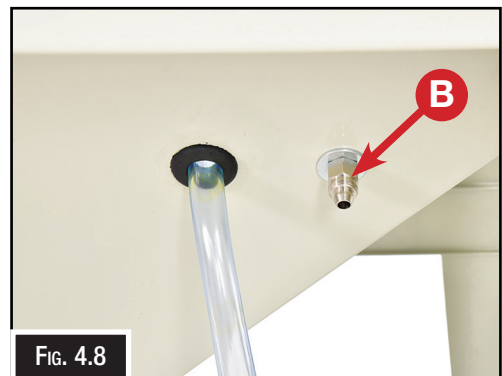
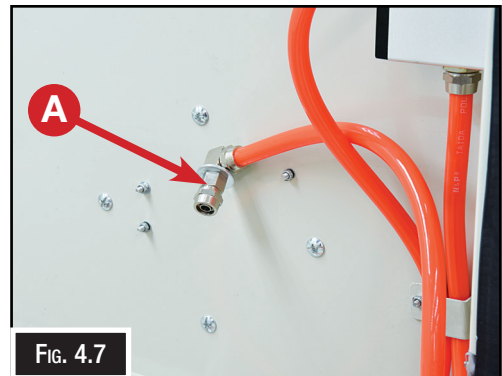

Dust Collector Assembly

11. Remove the motor filter assembly from the canister unit to facilitate assembly.
12. Attach the dust collector canister to the rear panel (left side when viewed from the back of the machine). Insert the inlet tube into the grommeted hole at the rear of the machine, then secure the two brackets to the machine using the four screws and nuts (F) provided. (See Fig. 4.10)
13. Locate the spring-loaded plunger assembly and disassemble it. From inside the canister, insert the threaded end of the plunger rod through the hole. On the outside of the canister, fit the spring, then the lock nut, and screw on the threaded plate knob approximately 10 mm. Finally, lock the assembly in place on the shaft using the lock nut. (See Fig. 4.11)
14. Refit the motor filter assembly on top of the canister and secure it in place using the two clips. (See Fig. 4.12)
15. Remove the conduit cover (G) and route the dust collector power lead inside, then reinstall the cover. Connect the dust collector power plug (H) to the socket located on the rear of the switch box. (See Fig. 4.13)

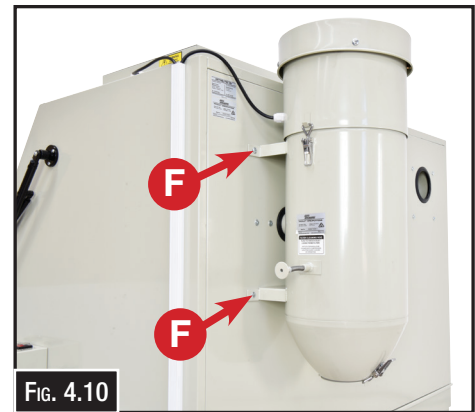

FIG. 4.10



FIG. 4.11



FIG. 4.12



FIG. 4.13

4.6 ASSEMBLY CONT.

15. At this stage, recheck that all nuts, bolts, and fasteners are properly tightened.
16. Place the work tables into the cabinet, so the work table with a corner cut off is positioned at the front right corner of the blast cabinet. (Fig. 4.14, 4.15)
17. Route the blast gun hoses through the notch in the right side of the table, and hang blast gun on its hook on right side of cabinet wall, (Fig. 4.15)
18. Check that the plastic PVC dust sheets have been attached to the inside of the cabinet viewing window and the lamp window. If blasting operations begin without these dust sheets installed, media will permanently etch the window glass and require the glass to be replaced. (Fig. 4.16)
19. **Connect Air Supply (See page 17)**
20. Select the type of media required and pour the desired amount into the cabinet through front door.
21. Inspect all seals, hose clamps, glove clamps, and window seals for loose fittings, cracks or leaks. Correct as required.

Your unit is now ready for safe operation.

Operation may require **trial and error**, including adjustment of air pressure, media type, gun tip size, and metering valve settings. A larger gun tip will produce a wider spray area but will require more air and readjustment of the metering valve between tip sizes. **Always ensure the sandblast gun and metering valve are correctly adjusted for optimal performance.**



FIG. 4.14



FIG. 4.15



FIG. 4.16

Replacement LED Light Fitting

To order a replacement LED light assembly, quote: Order Code 7SC0029.



CAUTION!

It is impossible to cover all possible safety guidelines. Every workshop environment is different. Always consider safety first, as it applies to the individual working conditions. Always use this and any other machinery with caution and respect. Failure to do so could result in, serious personal injury or. damage to equipment

4.7 AIR SUPPLY

WARNING: Do not connect to high pressure bottle gas, rupture and explosion can occur.

Air compressors are normally rated with an output measurement of either Cubic Feet or Litres per minute of compressed air which affects sandblasting due to sandblasting cabinets requiring a large volume of air for them to perform at their optimum.

The compressors output of air refers to the volume or amount of compressed air an air compressor can produce based on the size of the pistons, within the compressor pump, & the horsepower of the motor to drive this pump. PSI or pounds per square inch is a measurement of pressure which is completely different to CFM/LPM (volume) & it is the larger volume of air that is required for a sandblast cabinet & not high pressure that is required.

Some abrasive blasting cabinets can operate on a 240-volt air compressor, but these generally have a smaller size sandblasting gun which do not require a large volume of air to operate correctly but they also take longer to sandblast an item due to the limited size of the nozzle & the amount of blast media the gun is able to expel during blasting. A larger gun will blast much more quickly but it will also require a larger volume of air to perform at its optimum usually requiring a larger 415-volt air compressor with sufficient output of air to blast effectively & efficiently.

It is recommended that the minimum diameter hose used, to connect the compressor to the sandblast cabinet, be at least $\frac{3}{4}$ " (19mm) hose to ensure adequate flow of air volume to your cabinet. It is also recommended that a suitable water separator or filter be installed close to the sandblast cabinet to ensure the air, coming from the air compressor, is clean & dry.

Connecting To The Air Supply

When connecting the air supply, remove any in-line oilers, make the supply line long enough to allow the compressed air to fully cool before it reaches the gun. Install an in-line water separator or air dryer. Tilt the air supply lines slightly back toward the compressor so residual condensation in the lines will run back to the tank instead of the media blasting unit.

1. Connect the air line from the compressor to the regulator (A) that is fitted to the leg of the blast cabinet. (Fig. 4.17)

Note: If after operating the machine for the first time, the regulator gauge needle drops more than a few PSI when you press the foot pedal, check that the air supply is not restricted.

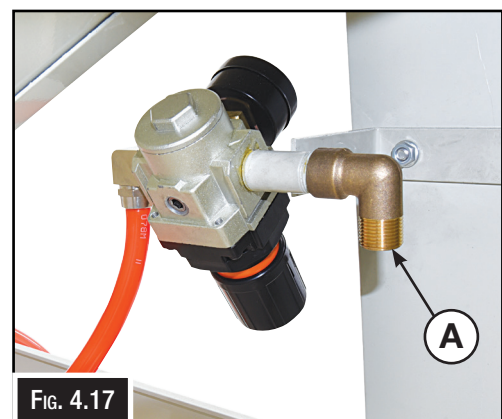

CAUTION!

Compressed Air is Dangerous and can cause Death or Injury if misused. Always bleed off the airline before disconnecting from the compressor or machine. DO NOT use compressed air to blow dust from clothes

5. OPERATION

5.1 CONTROLS

The purpose of this control overview is to provide the novice machine operator with a basic understanding of how the machine is used during operation, and the machine controls and what they do. It also helps the operator to understand if they are discussed later in this manual.

NOTE: DO NOT start the machine until all of the setup instructions have been performed.

Operating a machine that is not setup may result in malfunction or unexpected results that can lead to serious injury, death or damage to the machine or property.

1. **LIGHT ON/OFF Switch:** Switches on the light, in the cabinet. (Fig. 5.1)
2. **DUST COLLECTOR Switch:** Switches ON/OFF the dust collector. (Fig. 5.1)
3. **Pressure Gauge:** Displays the air pressure supplied to the machine. (Fig. 5.2)
4. **Air Pressure Adjustment:** Adjusts the air pressure supplied to the machine. (Fig. 5.2)



FIG. 5.1

To Adjust:

- a) Pull knob (H) out.
 - b). Rotate knob until the desired setting is reached.
- Note: The needle will not move (G), and the new setting will not display until the machine foot pedal is operated.

When the correct air pressure is set, push knob (H) back in.

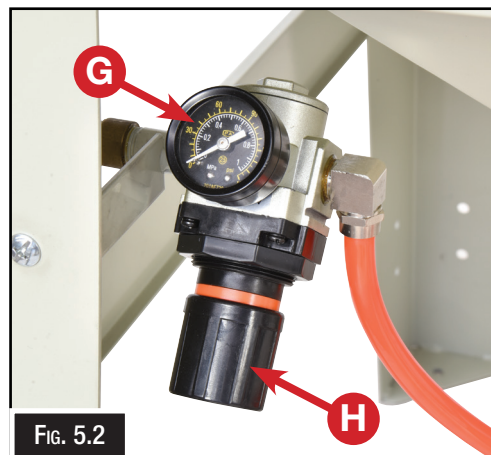

FIG. 5.2

5. **Foot Switch:** Activates the blast gun when pressed. (Fig. 5.3)

NOTE: The **cabinet door must be closed**. This engages the safety interlock on the door, allowing the sandblast machine to operate safely.



FIG. 5.3



WARNING!

Compressed Air is Dangerous and can cause Death or Injury if misused. Always bleed off the airline before disconnecting from the compressor or machine. DO NOT use compressed air to blow dust from clothes.

6. Abrasive Metering Valve (Fig. 5.4)

The metering valve may require fine adjustment to achieve optimum performance, depending on the type of media and nozzle size used.

- a. **Start the sandblaster** with the foot pedal pressed. While operating, look underneath the machine and observe the clear supply tube leading up to the unit (I).
- b. **Fully close the metering bolt** by screwing it all the way in (J).
 - In this position, with the foot pedal still pressed, the media will collect, surge and pulse.
 - This indicates that too much media is being drawn in and not enough air is being mixed with it in the riser tube.
- c. **Slowly open the metering bolt (J)** until the blasting media begins to move smoothly and steadily through the riser tube.
 - Continue opening the valve (J) until the surging and pulsing stop.
 - Around this position, the flow can be fine-tuned for best performance.
- d. **Avoid over-opening the valve.**
 - If opened too far, the flow of grit will decrease and eventually no media will be drawn through the system.

NOTE: To prevent the metering bolt (J) from moving out of adjustment due to vibration, it is recommended to apply a small amount of “**low-strength, removable thread locker**” to the internal thread (K).

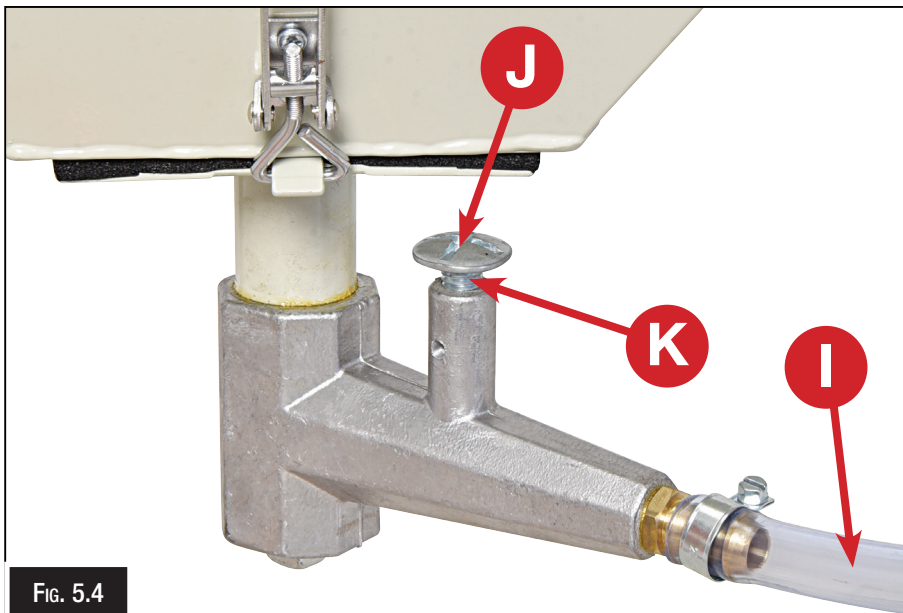

FIG. 5.4



WARNING!

NEVER use the sand blast cabinet with the door open, or point the gun at yourself or anyone else. When servicing this machine disconnect the power and the air hose. Ignoring this warning may lead to severe injury.

7. Sandblast Gun Adjustment

Your sandblast gun comes ready to use, but you may need to adjust it to suit your setup and get the best performance.

How to Adjust: (Fig. 5.6)

1. Release the Air Line Lock Nut (L) and temporary slide it down the air line (O) out of the way. This will allow the air line to spin freely on the fitting, making adjustment easier.
2. Using a spanner, loosen the locknut (N).
3. Turn the Air Inlet fitting (M) in or out. This adjusts the flow of media.
 - Start by turning the air inlet fitting (M) out to approximately 5mm.
4. Tighten the locknut (N) once the fitting is in the desired position.
5. Re-fit and secure the lock screw (L) to lock the air line (O) in place.

Helpful Tips: (Fig. 5.7)

- The Air Inlet fitting (M) has about **25mm of media flow adjustment**.
- Finding the best setting is a **trial-and-error process**. Adjust until the gun works efficiently for your needs.
- Always tighten the Air Line Lock Nut (L) once you've found the best position.

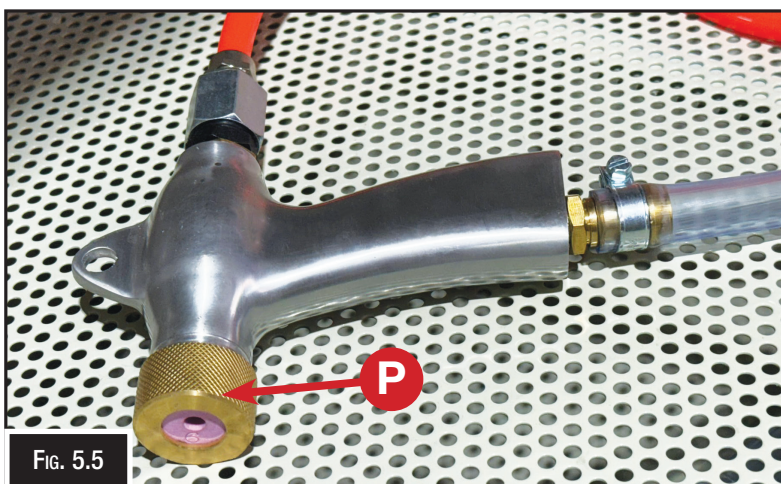

FIG. 5.5

Changing the Nozzle:

1. Release the Nozzle Nut (P) and remove the nozzle.
2. Replace the nozzle with the desired size.
3. Re-fit and tighten the nozzle nut (P) securely.

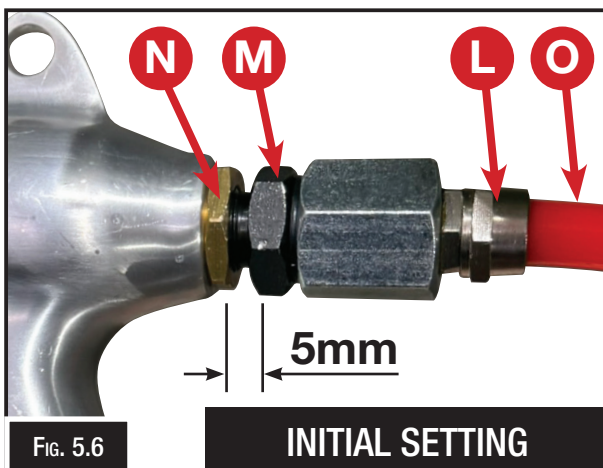

FIG. 5.6

INITIAL SETTING

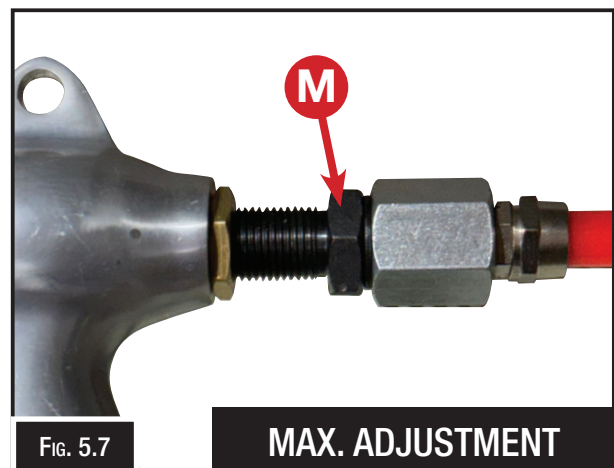

FIG. 5.7

MAX. ADJUSTMENT

5.2 BASIC OPERATION

Listed below is the order in which a normal operation for the SBC-990 Blast Cabinet is carried out.

NOTE: Before using the blast cabinet the first time, fit the window protective film to the inside of the light and glass windows if not factory fitted.

1. Check the window protective film for holes or excessive etching. Replace the sheets BEFORE they are worn through and the window is damaged.
2. Inspect all fittings and hoses for leaks. Inspect for damaged or leaking door seals. Make sure water separators are drained and make sure the dust collector is empty and the filter is clean.
3. Put on safety goggles and a respirator.

NOTE: To reduce your exposure to Dust Particles: Work in a well ventilated area, and work with approved safety equipment, such as those dust masks that are specially designed to filter out microscopic particles.

4. Select the blasting media and load it through door so that it is approximately 250mm above the metering valve.

NOTE: Never use media that contains free silica, as this is a leading cause of silicosis.

5. Select and install the required tip into the blast gun. (Usually 6mm) (Fig. 5.8)

NOTE: Tips available for this machine are 6mm and 7mm. As a general rule, your nozzle orifice minimum should be 3 times the size of the grit. When media blasting thin materials made of aluminum, copper, brass, wood, or other delicate parts, select the correct media and begin blasting at a low pressure, such as 45PSI. Next, slowly increase the air pressure until you achieve the finish required. When using some types of glass bead media, you may have to keep the operating pressure between 50-80PSI, or the media will break down prematurely.

Some media like silicon carbide and aluminium oxide can withstand pressures of up to 120PSI on this machine; however, most media blasting operations should occur at 80PSI.



FIG. 5.8

6. Turn the regulator knob to adjust the air pressure to the desired setting. This is a trial and error process, but a good place to start is a pressure between 90-120PSI. (Fig. 5.9)

To Adjust:

- a) Pull knob (H) out.
 - b). Rotate knob until the desired setting is reached.
- Note: The needle will not move, and the new setting will not display until the machine foot pedal is operated.

When the correct air pressure is set, push knob (H) back in.

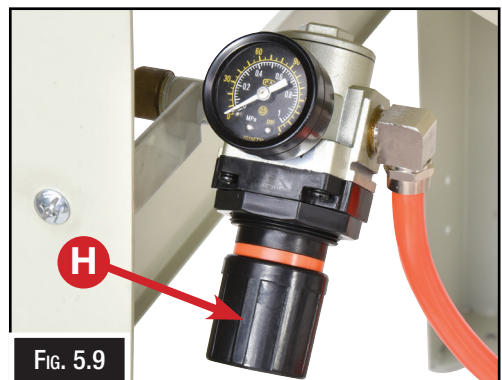

FIG. 5.9



DANGER!

It is impossible to cover all possible hazards. All operational environments are different. Never use media that contains free silica, as this is a leading cause of silicosis. Always consider safety first, as it applies to the individual working conditions.

5.2 BASIC OPERATION CONT.

7. Clean the workpiece of any oil or grease and place in the blast cabinet. Close the door, then move the latches until the door is completely locked.
8. Push the power switch ON, to start the dust collector and turn ON the work light. (Fig. 5.10)
9. Grip the hand gun (Fig. 5.11). Direct gun at parts at 45-60 degree angle with ricochet towards the back of the cabinet. Do not hold gun at 90 degree angle to parts being processed. This will cause the media blast to bounce back into the blast stream and slow blasting action. Also 90 degree angle will cause excessive wear on gun and viewing window. Hold gun approximately 6 inches from parts being blasted.

The gun must always be pointed away from the operator and towards items being processed. Never blast with any of the cabinet doors open. While loading and unloading, no one should be at the operator station, at the front of the blast cabinet.

- Cabinets are available with safety doors so that the gun cannot be operated unless the doors are closed.

10. Press the foot pedal (Fig. 5.12) and abrasive media will begin spraying from the blast gun tip. Move the blast gun in a slow circular motion.
11. During operation, periodically push the canister plunger firmly several times to remove material caked onto the outside of the filter. For prolonged use, service the dust collector filter every five hours of cabinet operation. (Fig. 5.13)
12. The blasting media can be changed by releasing the bottom hatch in the base of the hopper. (Fig. 5.14)

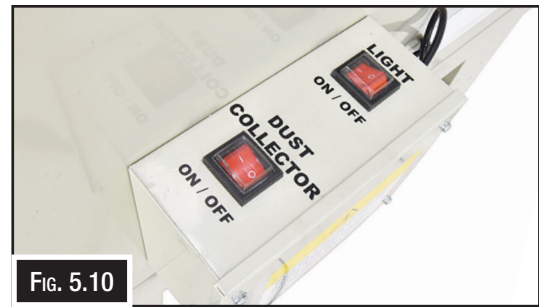

FIG. 5.10



FIG. 5.11



FIG. 5.12



FIG. 5.13



FIG. 5.14



WARNING!

NEVER use the sand blast cabinet with the doors open, or point the gun at yourself or anyone else. When servicing any part of this machine disconnect the power and the air hose. Ignoring this warning may lead to severe injury.

5.3 BLASTING MEDIA

Using low-cost media, such as basic builder's sand or play sand, is not recommended since sand is dull and does not have the cutting power. Excellent productivity can be achieved using sharp media listed below. Media should be of good quality and dry. Moisture will cause the media not to flow and will clog metering valve and hopper.

GARNET

Depending on your required finish, there is an ideal garnet grain size for your job. Here's what to know. For general applications when a surface profile above 75 microns is specified, the 30/60 mesh garnet abrasive is the ideal industry standard garnet grade. When you remove thick, soft coatings, the surface may absorb the energy before the garnet grains achieve full impact potential. Therefore, the heavier features of larger grain garnet can be more effective. For this application 20/40 grit size is available.

INDA GLASS BEAD

Bead blasting is one type of shot blasting. This process releases, at high pressure, fine glass beads to clean or finish a surface. In this process, a bead blaster shoots bead-shaped media from a high-pressured tool towards the material's surface. A bead blast finish aims to leave a smooth, shiny, and cleaner surface.

RECOMMENDED BLASTING MEDIA

20/40 Coarse Grade Garnet is suitable for removal of thick coatings and extreme rust. 20-40 Garnet enables high productivity rates and an exceptional surface finish. Cuts the surface and is suitable for preparing surfaces for coating applications. Has Increased recyclability, reducing cost and waste.

30/60 Mesh Premium Abrasive is a versatile product for removal of medium to heavy grade coatings or rust. Can be used for a wide variety of applications. It enables high productivity rates and an exceptional surface finish. Is suitable for Steel or cast iron.

-300/+106 Glass Beads is one of the most popular forms of blast media and can be used on a variety of projects. Glass beads are used for general cleaning, peening and cosmetic finishing of sensitive metal surfaces. Achieves a smooth, bright finish. Glass beads are the best option where fine polished finishes are required. Glass beads are also recyclable and can be used up to 100 times before replacement, making them an extremely cost-effective option. Glass bead media works well on soft metals like aluminium and brass as well as plastic.

SANDBLASTING BEADS
GARNET
20 - 40 COARSE BEADS 25KG
ORDER CODE S295



SANDBLASTING BEADS
GARNET
30 - 60 MEDIUM BEADS 25KG
ORDER CODE S296



SANDBLASTING BEADS
INDA-300 + 106 INDA (GLASS BEAD)
25KG
ORDER CODE S297



WARNING!

When operating a Blast Cabinet it is important to wear appropriate safety gear to protect yourself from injury. This includes an approved safety respirator, to protect your chest and safety glasses to protect your eyes.

5.4 TROUBLESHOOTING

1. **Blast Gun.** After 10 to 12 hours of blasting time, the Nozzle should be checked. If it shows uneven wear it should be turned 1/4 turn every 10 hours of use. Replace as needed.
2. **Caking of media.** Media caking is caused by moisture in the air supply or from oily or greasy parts. If not corrected the media will not flow evenly and will block the system. Check the air supply. If water is present, install a quality moisture trap. If oily or greasy parts are being blasted, degrease and dry the part first.
3. **Reverse pressure.** If the media stops flowing use an object to plug the Nozzle and press the Foot Pedal down for about two seconds. This will cause the system to back blast. This will help loosen any clogs. DO NOT use a finger to block the gun.
4. **Air supply.** If the pressure gauge on the regulator shows an adequate no-load supply (when the blaster is not running), press the foot pedal. If the pressure drops more than a few PSI your air supply is restricted or inadequate. Clean filters and moisture separators all the way back to the air compressor. Straighten any kinky lines. Use a master gauge to check the air pressure or replace existing gauge if you suspect it is giving you false readings.
5. **Blast Gun air pressure drop.** Turn the Air Regulator Knob and set the air pressure to 80 PSI as indicated on the Pressure Gauge. This could also indicate the air supply hose is too small, The air supply line should be 12mm diameter or larger.
6. **Poor visibility** (viewing window). The Glass Window is equipped with a clear plastic protector on it and may become pitted. If necessary, replace the plastic protector and/or Glass Window.
7. **Poor media flow.** Check for moisture. Holes in the media hose will also cause poor media delivery. If necessary, replace the hose. Debris in the media can also cause slow media flow. Replace or screen media.
8. **Dust collector.** Inadequate cabinet ventilation results in reduced cleaning power at the nozzle as well as diminished view of the work in progress. Use the dust collectors shaker every 20-30 minutes when the cabinet is turned off, (more often in dusty conditions. Empty dust collector at least once a day. Remove filter and blow out occasionally to keep the dust collector or vacuum working efficiently.
Replace as needed.

6.0 MAINTENANCE

It is very important that regular maintenance of the equipment is carried out. The operators need to follow the daily maintenance procedures.

For optimum performance from this machine, the maintenance schedule listed below and in this section must be followed.

6.1 SCHEDULE

Daily Check

- Loose mounting bolts or fasteners.
- Worn, frayed, cracked, or damaged wires.
- Damaged ON/OFF switches
- Push the canister plunger and release to remove caked on dust in the filter.
- Check and clean if necessary filter cartridge
- Any other condition that could hamper the safe operation of this machine

Monthly Check:

- Check all fasteners and clamps are tight.
- Inspect suction lines carefully for spots that collapse or leak during operation.
- Clean/vacuum dust buildup from inside cabinet and off the motor.
- Empty cabinet, wipe down inside and inspect for leaks or damage.
- Cover windows and repaint bare metal portions of cabinet.
- Inspect work gloves for holes or wear.
- Remove the filter and clean or replace as require

6.2 CLEANING THE FILTER

For major cleaning or replacement of the filter,

1. DISCONNECT THE MACHINE FROM THE POWER.
2. Unplug the power to the motor and unlatch the top of the dust collector and remove the motor, then the filter element. (Fig. 6.1)
3. Inspect all sealing foam and replace as required.
4. Clean the filter canister pleats outside in the open by carefully blowing it from the inside out with compressed air.
5. If usability of the filter is in question, or any holes or tears exist, replace it. (**Order Code: 2SC0562**) See page 26.



WARNING!

When cleaning the cabinet or the filter, wear a respirator and safety goggles. Failure to comply can cause serious personal injury.

7.0 RECOMMENDED ACCESSORIES

#1~7 - SANDBLASTING GUN

Order Code: 3SC0300



#2 - CERAMIC NOZZLE 6MM PKT 2

Order Code: 3SC0206



#2 - CERAMIC NOZZLE 7MM PKT 2

Order Code: 3SC0207



FILTER DUST COLLECTOR - #29

Order Code: 2SC0562

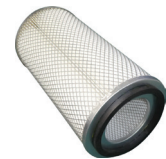

Sandblasting Beads - Garnet
30 - 60 Medium Beads (25kg)

Order Code: S296



Sandblasting Beads - Garnet
20 - 40 Coarse Beads (25kg)

Order Code: S295



Sandblasting Beads - Inda
-300 + 106 INDA (Glass Bead) (25kg)

Order Code: S297



#24 - PVC SHEET PKT 4 (MAIN WINDOW)
670MM X 300MM

Order Code: 7SC0024



#30 - PVC SHEET PKT 3 (LIGHT)
900MM x 260MM

Order Code: 7SC0030



#15 - GLOVES PAIR
Order Code: 2SC0035



SB-C870 - Industrial Sandblasting
Dust Cyclone Extractor
2 Stage Filtration System
Order Code: S310



SANDBLAST CABINET

SBC-990

Order Code: (S305)

The following section covers the spare parts diagrams and lists that were current at the time this manual was originally printed. Due to continuous improvements of the machine, changes may be made at anytime without notification.

HOW TO ORDER SPARE PARTS

1. Have your machines model number, serial number & date of manufacture on hand, these can be found on the specification plate mounted on the machine.
2. A scanned copy of your parts list/diagram with required spare part/s identified.

NOTE: SOME PARTS MAY ONLY BE AVAILABLE AS AN ASSEMBLY

3. Go to www.machineryhouse.com.au/contactus and fill out the inquiry form attaching a copy of scanned parts list.



WARNING!

*Electricity is dangerous and could cause death.
All electrical work must be carried out by a qualified electrician.*



CAUTION!

It is impossible to cover all possible hazards Every workshop environment is different. These are designed as a guide to be used to compliment training and as a reminder to users prior to equipment use. Always consider safety first, as it applies to the individual working conditions.

CABINET - PARTS DIAGRAM 1

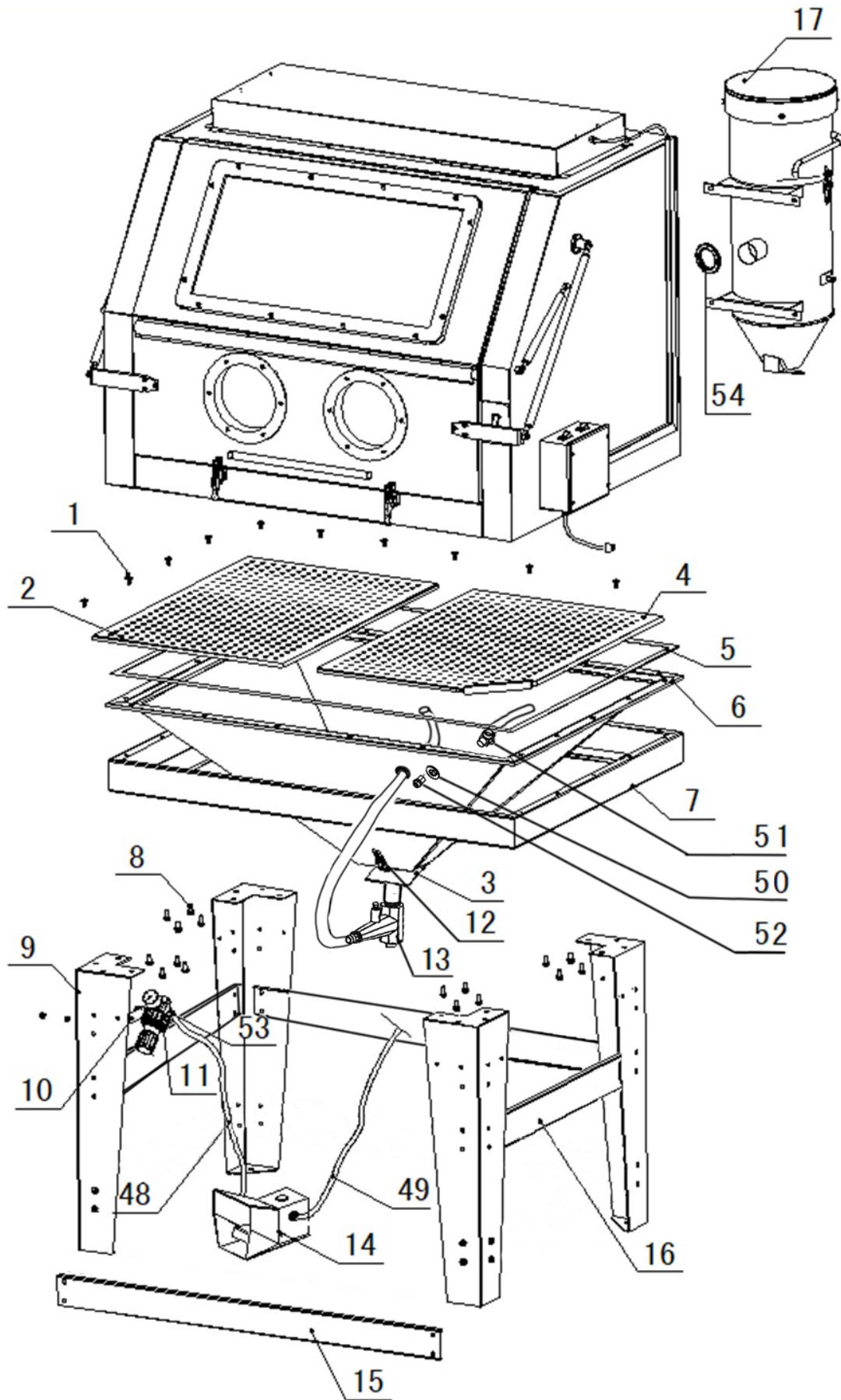

CABINET - PARTS DIAGRAM 2

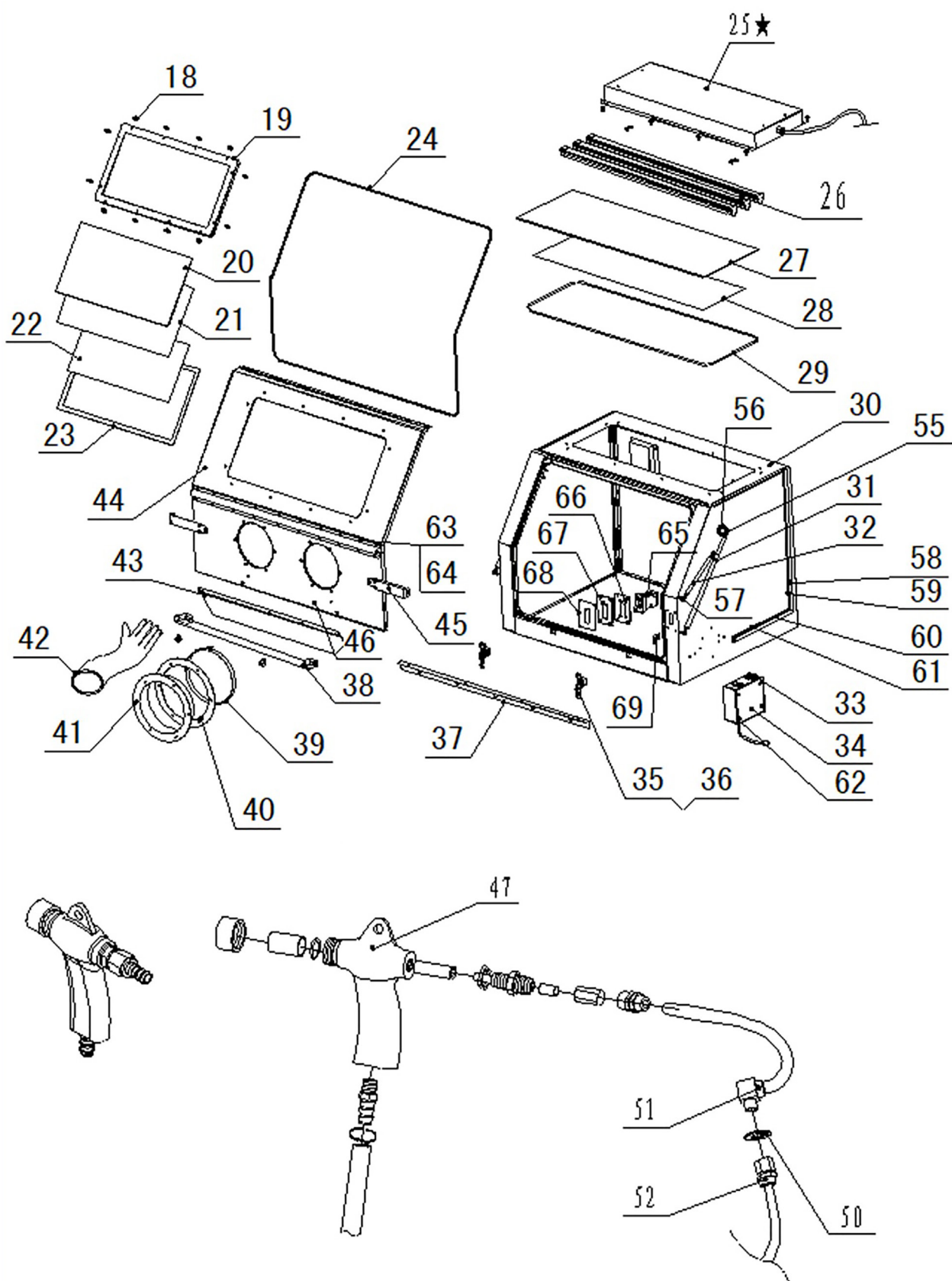

CABINET - PARTS LIST

ITEM	DESCRIPTION	QTY
1	ROUND HEAD CROSS SCREW	22
	FLAT WASHER	22
2	LEFT GRID	1
3	HOPPER BOTTOM DOOR	1
4	RIGHT GRID	1
5	SEALING TAPE	5
6	HOPPER	1
7	BRACKET	1
8	HEX. SCREW	32
	FLAT WASHER	32
	SPRING WASHER	32
9	LEG	4
10	REGULATOR BRACKET	1
11	AIR GAUGE - REGULATOR	1
12	ASSEMBLED LATCHES	1
13	METERING VALVE	1
14	FOOT PEDAL	1
15	LEG REINFORCES 1	2
16	LEG REINFORCES 2	2
17	DUST COLLECTOR	1
18	ROUND HEAD CROSS SCREW	12
19	BRACKET OF VIEWING WINDOW	1
20	GLASS BOARD OF VIEWING WINDOW	1
21	GLASS OF VIEWING WINDOW	1
22	VIEWING WINDOW PROTECTIVE FILM	6
23	SEALING TAPE OF VIEWING WINDOW	
24	RUBBER SEAL STRIP OF FRONT OPENING DOOR FRAME	1
25	COVER ASS'Y FOR LED LIGHT	1
26	LED LIGHT	3
27	GLASS OF LIGHT WINDOW	1
28	LIGHT WINDOW PROTECTIVE FILM	6
29	RUBBER SEAL STRIP OF LIGHT WINDOW	1
30	UPPER CABINET	1
31	MAIN SUPPORT POLES	2
32	SUPPORT POLE OF AIR SPRINGS	2
33	ELECTRIC BOX	1
34	COVER FOR ELECTRIC BOX	1
35	FRONT DOOR LATCH	2
36	LATCH SEATS	2
37	RACK BOARD	1
38	GRIP	1
39	LARGE HOSE CLAMPS	2
40	MOUNTING RING OF GLOVES	2
41	GLOVES SEAT	2
42	GLOVES	1
43	SAND BOARD	1
44	ELEMENTS OF FRONT OPENING DOOR	1
45	SUPPORT BOARD OF FRONT DOOR	2

NOTE: SOME INDIVIDUAL PARTS MAY ONLY BE AVAILABLE AS AN ASSEMBLY

CABINET - PARTS LIST CONT.

ITEM	DESCRIPTION	QTY
46	WELDED BRACKET FOR FRONT DOOR	1
47	SAND GUN	1
48	AIR HOSE (ORANGE)	2
49	AIR HOSE (ORANGE)	1
50	LOCK NUT	1
51	L-QUICK CHANGE COUPLING (METAL)	1
52	QUICK-CHANGE COUPLING (METAL)	1
54	RUBBER RING	1
55	WASHER	6
56	BRACKET FOR MAIN SUPPORT POLE	2
57	SEAT FOR SMALL POLE	2
58	CABLE BOTTOM COVER A	1
59	CABLE TOP COVER A	1
60	CABLE BOTTOM COVER B	1
61	CABLE TOP COVER B	1
62	SELF-TAPPING SCREW	4
63	RUBBER BOARD FOR FOLDING DOOR	2
64	RUBBER BOARD FOR FOLDING DOOR	1
65	CONTROL VALVE ASS'Y	1
66	FIXING PLATE FOR VALVE	1
67	SEAL FOR VALVE	1
68	COVER FOR VALVE	1
69	FIXING PLATE FOR AIR HOSE	1

NOTE: SOME INDIVIDUAL PARTS MAY ONLY BE AVAILABLE AS AN ASSEMBLY

WIRING DIAGRAM

L PHASE WIRE

N NEUTRAL WIRE

PE EARTH WIRE

F FUSE

E LUMINAIRE WITH FOUR
FLUORESCENT TUBES

X1 CONNECTOR

X2 CONNECTOR

S1 LIGHT SWITCH

S2 MOTOR SWITCH

M MOTOR

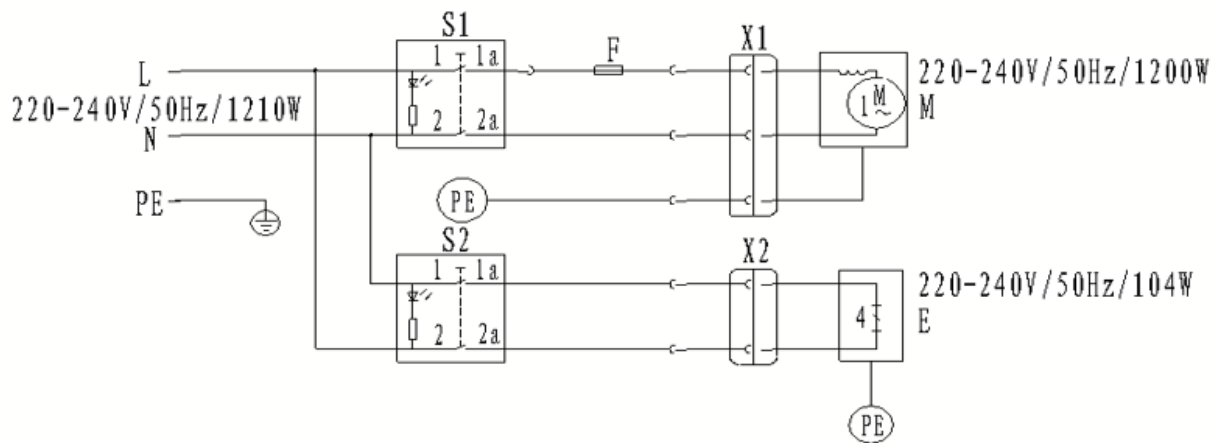



ENVIRONMENT PROTECTION

Recycle unwanted materials instead of disposing of them as waste. All tools, accessories and packaging should be sorted, taken to a recycling centre and disposed of in a manner which is compatible with the environment. When the product becomes completely unserviceable and requires disposal, drain any fluids (if applicable) into approved containers and dispose of the product and fluids according to local regulations.

IMPORTED BY



Australian Distributor

**Hare & Forbes
Machineryhouse**
Sydney - Melbourne
Adelaide - Brisbane - Perth

Ph: 1300 202 200
www.machineryhouse.com.au



New Zealand Distributor

Machineryhouse
Auckland
Christchurch

Ph: 0800 142 326
www.machineryhouse.co.nz